

Inspiration For Outdoor Living™

**Decorators®**  
Lighting





Black Lighted Square Balusters and Black Aluminum Estate Balusters with Aluminum Copper Light Band Post Caps. Shown with Deckorators Aluminum Railing.

Enjoy your deck late into the evening with Deckorators Lighting, a stylish collection of low voltage lighting options to accent your railing, balusters and deck. Each features LED lighting, making this system energy efficient and inexpensive to run. Besides creating a show-stopping deck, Deckorators Lighting provides a sense of safety, illuminating stairways and railings without flooding your deck with light.

Designed with flexibility in mind, each component can be installed with others or independently to meet the needs of any project, big or small. Each piece was designed to coordinate beautifully with the full line of Deckorators railing and accessories.

### Lighted Aluminum Balusters

Add a dazzling glow to your deck railing with lighted aluminum balusters. Available in two styles – Round Willow or Square – and powder-coated in black or white. Each baluster features LED lights that shine through stylish eye-catching designs. Connectors are included with each 3-pack baluster kit for streamlined installation. Want to change it up? Mix and match lighted balusters with Deckorators Classic or Estate balusters, using special baluster mounting hardware.



Black Willow Lighted Balusters

### Post Cap Lights

Top off your railing with low voltage post cap lights. With a style to match almost any décor, Deckorators post cap lights are available in Tiffany-style Mission, contemporary Light Band and traditional glass styles. Choose from 4x4 aluminum bases in black or white or VersaCap bases which fit most posts ranging from 3-1/2" to 4-5/8" square. Each post cap light includes 3 LED lights, a 6' pigtail wire attached to the light and a cable connector – everything needed for a successful installation.



Tiffany-style Mission Post Cap



Black Light Band Post Cap



Copper Light Band Post Cap



Black Glass Post Cap

### Recessed Lights

These compact, ultrabright low-voltage LED lights make decks both appealing and accessible after dusk. They mount flush to any surface and are ideal for pathways, stairs, doorways and step-downs. Versatile and easy to install, recessed lighting is a simple way to add a dramatic effect to your deck.



Recessed Lights



Black Lighted Square Balusters and Black Aluminum Estate Balusters with Aluminum Copper Light Band Post Caps. Shown on Decorators Aluminum Railing.

## Step 1 | Lighting Components | Aluminum Balusters | 2.5 Balusters per Lineal Foot

### A Lighted Aluminum Balusters

#### Lighted Square Baluster Pack

3 Lighted Square Balusters/Connectors included

141745 – 26" Black      141746 – 32" Black  
142116 – 26" White      142117 – 32" White

#### Lighted Willow Baluster Pack

3 Lighted Willow Balusters/Connectors included

141743 – 26" Black      141744 – 32" Black  
142114 – 26" White      142115 – 32" White

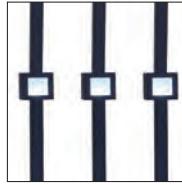

Lighted Square Aluminum Balusters

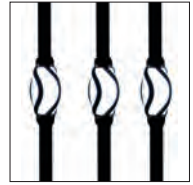

Lighted Willow Aluminum Balusters

### B Non-lighted Aluminum Balusters

#### Estate Baluster Pack

10 Estate Balusters/Connectors not included

95821 – 26" Black      118785 – 32" Black  
124352 – 26" White      124337 – 32" White

#### Classic Baluster Pack

10 Classic Balusters/Connectors not included

74698 – 26" Black      74719 – 32" Black  
74710 – 26" White      74731 – 32" White



Estate Balusters



Classic Balusters

### C Baluster Mounting Hardware

Use Baluster Mounting Hardware to install Estate or Classic balusters in combination with Lighted Aluminum Balusters

#### Estate Baluster Mounting Hardware Kit

141749 – Black      142120 – White

#### Classic Baluster Mounting Hardware Kit

141747 – Black      142118 – White



Estate Baluster Mounting Hardware Kit



Classic Baluster Mounting Hardware Kit

*(Baluster Stair Adaptor Hardware also available)*

### D Wire Covers

Use wire covers between square and round balusters for a clean look

143041 – Black Line      143042 – White Line  
143043 – Black Stair      143044 – White Stair



Line Rail



Stair Rail

### E Post Cap Lights

#### Tiffany-style Mission

141646 – Black Aluminum Base  
141647 – White Aluminum Base  
141668 – Black VersaCap  
141669 – White VersaCap

#### Light Band

141648 – Copper with Black Aluminum Base  
141651 – Copper with White Aluminum Base  
141645 – Black Aluminum Base  
141644 – White Aluminum Base  
141670 – Copper VersaCap  
141671 – Black VersaCap  
141672 – White VersaCap

#### Traditional

141673 – White VersaCap  
141674 – Black VersaCap



Tiffany-style Mission



Light Band

#### Available Colors

*Tiffany-Style Mission and Traditional Post Caps*

Black      White

#### Light Band

Black      White      Copper



Traditional

## Step 2 | Choose Transformer/Power Supply

Determine the total wattage of your low voltage lighting system by adding up the wattage of each fixture to be used. Purchase a transformer that will accommodate that wattage.

Component (each)	Wattage
Low Voltage Post Cap Light	1 Watt
Lighted Willow Baluster	0.27 Watts
Lighted Square Baluster	0.27 Watts
Recessed Light	0.47 Watts

Be sure the transformer wattage isn't too high for the system, as this could shorten the bulb life.

## Step 3 | Choose Low Voltage Cable

Determine the amount of cable required by measuring the distance from the furthest light, in series, back to where the transformer will be mounted. Be sure to factor in the distance of running the wire up a post sleeve or beneath a deck.

Use Cable	For length up to	For wattage up to
16 Gauge	50 feet	150 Watts
14 Gauge	150 feet	200 Watts
12 Gauge	200 feet	300 Watts

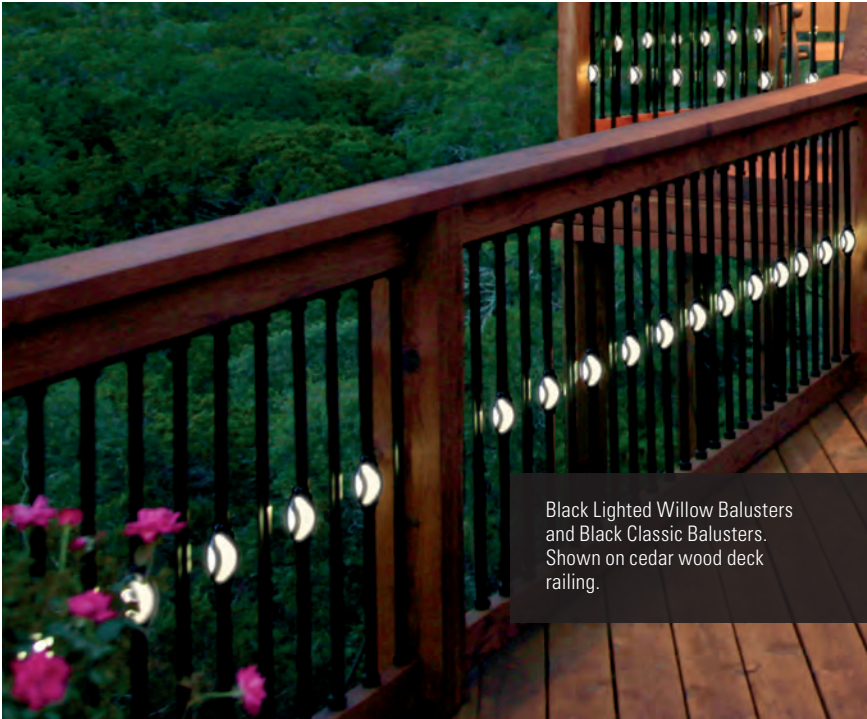

Black Lighted Willow Balusters and Black Classic Balusters. Shown on cedar wood deck railing.





White Lighted Willow Balusters and White Classic Balusters with Tiffany-Style Mission VersaCap Lights. Shown on Deckorators CXT Railing.



## General Information/ Safety Precautions

- Lighted Aluminum Balusters and Post Cap Lights are for use with a low voltage outdoor landscape power system with a maximum output rating of 12 volts, 156 watts per secondary. Recessed Lighting Kit components are for use with low voltage outdoor landscape power system with a maximum output of 15 volts, 300 watts per secondary.
- Warning – Risk of electric shock. Install all luminaries 10 feet or more from a pool, spa, or fountain.
- The main low voltage cable is intended for shallow burial – less than 6 inches (152mm)
- Check with your local regulatory agency for special code requirements in your area. If you are experiencing problems, contact a qualified electrician.
- Make sure the electrical current is turned off during installation.
- Outdoor use only.

## Tools Needed

- Drill/power screwdriver
- Assorted drill bits
- 2" Forstner bit
- Hammer
- Miter or circular saw with fine-tooth carbide tip blade
- Measuring tape
- Carpenter's pencil
- Wire cutters
- Clamps
- Safety glasses

- A = Lighted Aluminum Baluster
- B = Baluster Mounting Hardware
- C = Post Cap Light
- D = Recessed light
- E = Transformer
- F = Low Voltage Cable

## Preparing your Posts

You will need to prepare the top of your wood posts for the post cap lights. For new construction, trim the supporting wood post 2" shorter than the height of the post sleeve to house excess pigtail wire. For an existing railing or wood posts, drill a hole at least 2" deep in the center of the supporting post with a 2" Forstner bit.

## Wiring your Deck

There are multiple options for wiring a deck and many factors that will determine which is best. If you are installing our Lighted Aluminum Balusters, we recommend that you run the main low voltage wire beneath the top rail. Wiring may be done before or after rails are installed.

1. Drill 3/8" holes in the deck posts or post sleeves directly below the top rail bracket. (When installing onto the Decorators aluminum railing system, insert a plastic grommet (sold separately) into each drilled hole in the aluminum post sleeves).
2. Feed the cable from the transformer through each post or post sleeve and across the railing sections, leaving an extra loop of wire at the top of each post to attach post cap lights. See drawing for recommended wiring of deck.

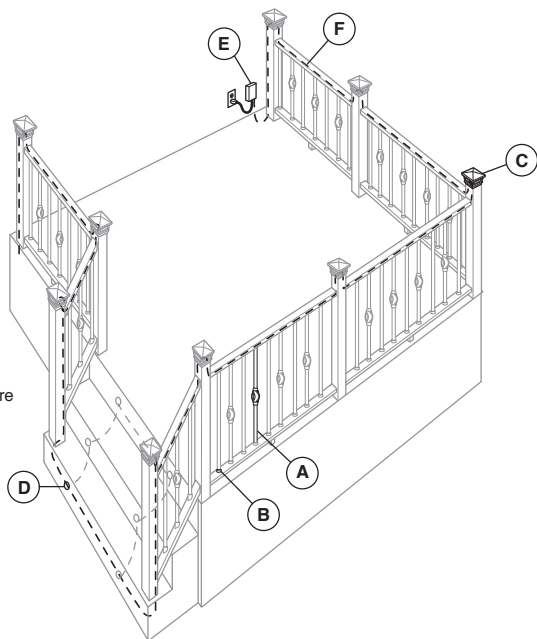

## Lighted Aluminum Balusters

(Square and Round Willow)

### Kit Contents:

- 3 - LED Lighted Aluminum Balusters
- 3 - Top Connectors
- 3 - Bottom Connectors
- 6 - Stainless Steel Screws

**Important Note:** If you are installing non-lighted Classic or Estate balusters in combination with Lighted Aluminum Balusters, you will use Decorators Baluster Mounting Hardware to connect the non-lighted balusters to the rail. Follow the same instructions for both lighted and non-lighted balusters, except where indicated.

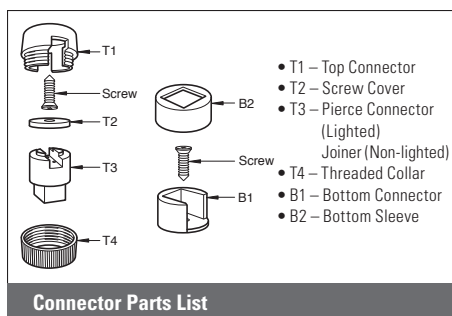

1. Measure railing opening.
2. Cut top and bottom rails to length and clamp together. Mark rails 4" on-center for Round Willow Balusters, or 4-3/8" on-center for Square Balusters, starting from the center of the rail.
3. Attach top connectors to rails.
  - a. **Lighted Balusters:** Unscrew the threaded collar (T4) from the top connector (T1) and remove top connector from baluster. Leave threaded collar on the baluster.
  - Non-Lighted Balusters:** Unscrew threaded collar (T4) from top connector (T1). Remove joiner (T3) from top connector.
  - b. Using one of the provided mounting screws, push the pointed end of the screw through the hole in the back side of the top connector to pop out the screw cover (T2). (Figure 3b)
  - c. Attach the top connectors to the top rail at the marked locations using the screws provided. Ensure the channels are aligned with the top of the rail to allow passage for wire. (Figure 3c)
4. Attach bottom connectors to rails.
  - a. **Lighted Balusters:** Remove the bottom connector (B1) from the lighted baluster by sliding the connector sleeve (B2) up the baluster.
  - Non-Lighted Balusters:** Remove bottom sleeve (B2) from bottom connector (B1).
  - b. Attach the bottom connectors to the bottom rail using the screws provided.
5. Attach top and bottom rails to posts following the instructions provided with the railing system. If you have not done so, drill 3/8" hole in the post sleeves directly below the top rail bracket.

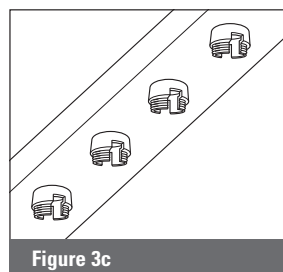
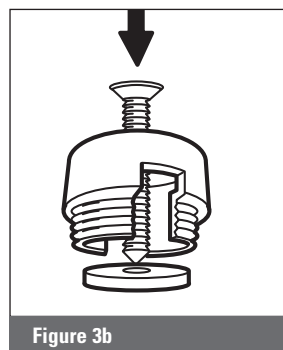

6. Reinstall screw covers previously removed in step 3.

**a. Covers screw head**

**b. Faces wire**

*Important – Screw Cover Installation*

The screw cover must be properly installed for the system to work. Improper installation of the screw cover will prevent the pierce connectors from making electrical contact with the wire. Elimination of this critical part from the assembly could result in an electrical short should the pierce connectors contact the metal head of the screw. The screw cover is intended to be installed with the hollow center facing the screw head (Figure 6). The opposite side of the cover forms the seat for the pierce connectors to contact the wire. The side that faces the baluster has a raised center and a raised outer edge, forming a channel between the inside and outside edge. The screw cover fits snugly when aligned and pressed into place. Access to the mounting screw for replacement of damaged rails or balusters will require the removal of the screw cover.

7. Feed main low voltage cable through post or post sleeve and across top connectors. (Figure 7)

8. Secure top of balusters.

**a. Non-Lighted only:** Slide threaded collar (T4) over top end of baluster. Insert joiner (T3) into top end of baluster.

**b.** Insert joiner/pierce connector (T3) end of baluster into top connector and push firmly to pierce the wire. Secure to top connector by sliding threaded collar up to mate with threaded end of top connector. (Figure 8)

9. Secure bottom of balusters.

**a. Non-Lighted only:** Slide bottom sleeve (B2) over bottom end of connector.

**b.** Insert bottom end of baluster into slotted opening of bottom connector (B1) and slide until the baluster completely sits inside the connector. Slide connector sleeve down to cover bottom connector. Twist connector sleeve until firmly secured. (Figure 9)

10. Optional: Cover exposed wire by installing Deckorators wire covers. Attach wire covers between top rail connectors and secure with 2 screws provided.

11. For Stair Installation, follow the steps above, with the following changes:

**a.** Mark top and bottom rails 5" on-center for Willow balusters, or 5-7/16" on-center for Square balusters, starting from the center of the rail.

**b.** You will install a top stair connector (ST1) instead of the top connector (T1) to the top rail. (Figure 14a)

**c.** You will install a bottom stair connector (SB1) instead of the bottom connector (B1) to the bottom rail. (Figure 14c)

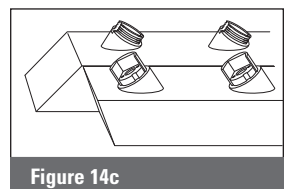
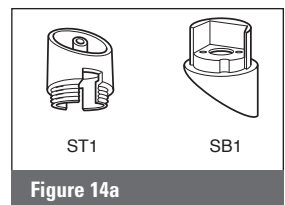
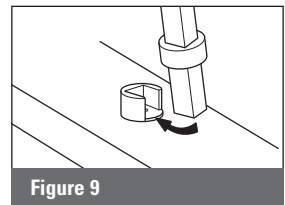
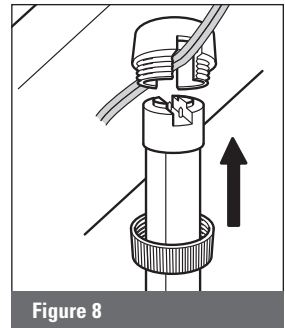
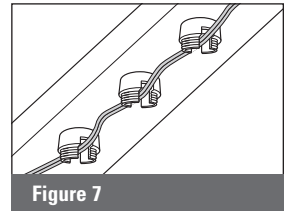
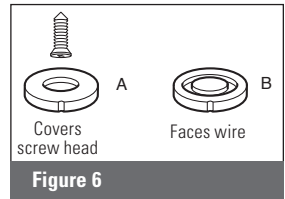

## Low Voltage Post Cap Lights

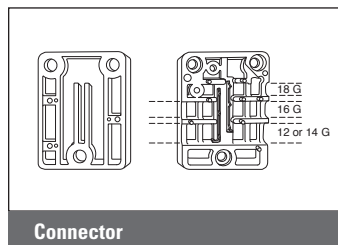
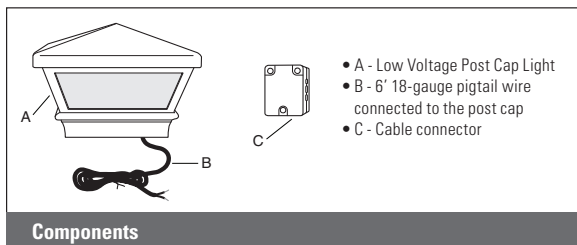

1. Prepare the top of the post for the Post Cap Light. For new construction, trim the supporting post 2" shorter than the height of the post sleeve to house excess pigtail wire. For existing railing, drill a hole at least 2" deep in the center of the supporting post with a 2" Forstner bit.
2. Run your main low voltage cable either under the deck around the perimeter of the deck structure or beneath the top rail.
3. Cut the pigtail wire to the appropriate length, leaving an extra 1-1/2" of wire that will run inside the cable connector.
4. Connect the pigtail wire to the main low voltage cable using the included cable connector:
  - a. Remove the three screws and open up the connector.
  - b. Find the channel that is marked with the gauge of the main low voltage supply. Remove the channel insert and lay the main low voltage cable in the channel.
  - c. Insert the pigtail wire connected to the post cap light into the area marked 18G. The pigtail wire will terminate inside the connector.
  - d. Close the connector, reinsert the screws and tighten to close. This action causes the connector to pierce the wires.
5. Adjust the post cap frame by inserting or removing the included inserts so the post cap fits correctly on the post sleeve. Do not permanently attach the post cap at this point.
6. Connect the low-voltage cable to the transformer following the instructions provided with the transformer. Turn on power to verify the system works.
7. Turn off power. Apply construction adhesive to the underside of the post cap and place firmly on the post sleeve.

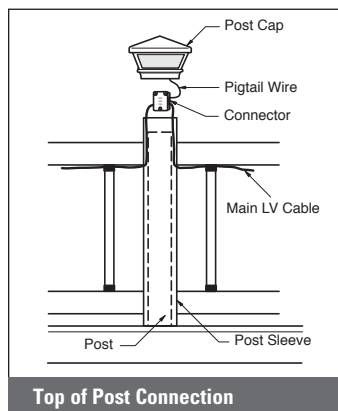

## Recessed Lighting Kits

1. Find a location for the transformer and photo sensor, which are weather resistant and intended for outdoor use. (Skip to step 3b if you are connecting to a main low voltage cable and transformer not included in the kit.)

- a. Do not install the photo sensor behind shrubs or too close to a light source. This will affect the photo sensor.

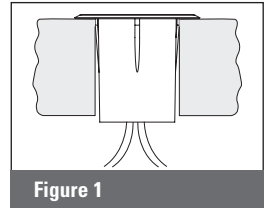

Figure 1

2. Mount the photo sensor.

- a. Mount the photo sensor with the included screw on a wall within one foot (30 cm) of the electrical outlet where the transformer will be connected.

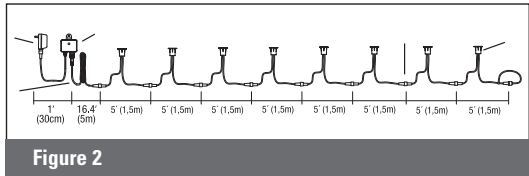

Figure 2

3. Position lights and run wire.

- a. The wire should run from the photo sensor or main low voltage cable without being cut. Do not run the wire within 10 feet (3m) of a pool, spa or fountain.
- b. Connect the extension wire (if using) and all light fixtures end-to-end, making one long wire connection. This is the distance available when positioning your lights.
- c. Position the light fixtures, making sure that the extension wire will reach the photo sensor. Once they are properly positioned, drill holes using the included 1" drill bit.
- d. Disconnect the lights from each other and insert each fixture into its corresponding hole by feeding the two (2) wires first then pressing the fixture firmly into the hole so that it fits tightly against the surface. Repeat this for all lights. (Figure 1)

4. Connect to the low voltage cable. (Skip to step 6 if you are using the transformer and photo sensor included in the kit.)

- a. Using a cable connector, connect the male end of the wire connected to the first fixture to the main low voltage cable (the connection should be made as close to the end of the fixture wire as possible), following the directions provided with the cable connector.
- b. Connect the female end of the wire from the first light fixture to the second light fixture, and each fixture to the next. (Figure 2)

5. Connect to the included transformer.

- a. Connect the male end of the extension wire to the "OUT" connection of the photo sensor.
- b. Connect the female end of the extension wire to the first light fixture and each fixture to the next. (Figure 2)

6. Connect the photo sensor and the transformer.

- a. Connect the photo sensor to the transformer.
- b. Plug the transformer into the electrical receptacle.

Additional two-pack add-on kits and extension wire available.



Scan code to learn more about Decorators Recessed Lighting Kit. Get the free mobile app at <http://gettag.mobi>

White Lighted Square  
Balusters, White Aluminum  
Estate Balusters with White  
Traditional Post Cap Lights.  
Shown on Deckorators  
CXT Railing.

## Deckorators® On The Web

facebook

Become a fan and post your thoughts on all things that inspire outdoor living. Share your Deckorators projects and stories on our fan page.

[Deckorators.com/Facebook](http://Deckorators.com/Facebook)

twitter

Follow Deckorators as we Tweet about new products, promotions and industry news.

[Twitter.com/Deckorators](http://Twitter.com/Deckorators)

You Tube

Visit the Deckorators YouTube channel to view the latest how-to videos, on location videos and more.

[Deckorators.com/YouTube](http://Deckorators.com/YouTube)



Check out our Decking and Outdoor Living blog for all things decking and outdoor living.

[Blog.ufpi.com](http://Blog.ufpi.com)



deckvisualizer

Design your dream deck online in minutes with Deckorators Deck Visualizer.

[Deckorators.com/Visualizer](http://Deckorators.com/Visualizer)

Pinterest

Visit our Deckorators Pinterest page for visual ideas on how to customize, relax and entertain on your deck.

[Pinterest.com/Deckorators](http://Pinterest.com/Deckorators)



Scan code to learn more about Deckorators.  
Get the free mobile app at <http://gettag.mobi>

Dec ~~K~~orators®  
Lighting

[deckorators.com](http://deckorators.com)  
800.332.5724

© 2012 Universal Forest Products, Inc.  
All rights reserved.

Deckorators is a registered trademark  
of Universal Consumer Products, Inc.,  
in the United States.

6965 6/12

The diagrams and instructions in this brochure are for illustration purposes only and are not meant to replace a licensed professional. Any construction or use of the product must be in accordance with all local zoning and/or building codes. The consumer assumes all risks and liability associated with the construction or use of this product. The consumer or contractor should take all necessary steps to ensure the safety of everyone involved in the project, including, but not limited to, wearing the appropriate safety equipment.  
EXCEPT AS CONTAINED IN THE WRITTEN LIMITED WARRANTY, THE WARRANTOR DOES NOT PROVIDE ANY OTHER WARRANTY, EITHER EXPRESSED OR IMPLIED, AND SHALL NOT BE LIABLE FOR ANY DAMAGES, INCLUDING CONSEQUENTIAL DAMAGES.